

GUARDIAN

FALL PROTECTION



Product Name: 2-Way Standing Seam Roof Clamp

Part #: 10600

Instruction Manual

Do not throw away these instructions!

Read and understand these instructions before using equipment!

Introduction	1
Applicable Safety Standards	1
Worker Classifications	1
Product Specific Applications	2
Limitations	2 - 3
Components and Specifications	4
Installation and Use	4 - 5
Compatible SSMR List	6 - 8
Maintenance, Cleaning, and Storage	9
Inspection	9
Inspection Log	9
Safety Information	10
Labels	11

Introduction

Thank you for purchasing a Guardian Fall Protection 2-Way Standing Seam Roof Clamp. This manual must be read and understood in its entirety, and used as part of an employee training program as required by OSHA or any applicable state agency.

This and any other included instructions must be made available to the user of the equipment. The user must understand how to safely and effectively use the 2-Way Standing Seam Roof Clamp, and all fall safety equipment used in combination with the 2-Way Standing Seam Roof Clamp.

User Information	
Date of First Use:	_____
Serial #:	_____
Trainer:	_____
User:	_____

Applicable Safety Standards

When used according to instruction specifications, this product meets or exceeds all applicable OSHA 1926 Subpart M and OSHA 1910 standards for fall protection. Applicable standards and regulations depend on the type of work being done, and also might include state-specific regulations. Consult regulatory agencies for more information on personal fall arrest systems and associated components.

Worker Classifications



Understand the following definitions of those who work near or who may be exposed to fall hazards.

Qualified Person: A person with an accredited degree or certification, and with extensive experience or sufficient professional standing, who is considered proficient in planning and reviewing the conformity of fall protection and rescue systems.

Competent Person: A highly trained and experienced person who is ASSIGNED BY THE EMPLOYER to be responsible for all elements of a fall safety program, including, but not limited to, its regulation, management, and application. A person who is proficient in identifying existing and predictable fall hazards, and who has the authority to stop work in order to eliminate hazards.

Authorized Person: A person who is assigned by their employer to work around or be subject to potential or existing fall hazards.

It is the responsibility of a Qualified or Competent person to supervise the job site and ensure all applicable safety regulations are complied with.

Product Specific Applications



WARNING Use of equipment in unintended applications may result in serious injury or death. Maximum 1 attachment per connection point.



Personal Fall Arrest: 2-Way Standing Seam Roof Clamp may be used to support a MAXIMUM 1 PFAS for use in Fall Arrest applications. Structure must withstand loads applied in the directions permitted by the system of at least 5,000 lbs. Maximum free fall is 6', or up to 12' if used in combination with equipment explicitly certified for such use. Applicable D-ring: Dorsal.



Restraint: 2-Way Standing Seam Roof Clamp may be used in Restraint applications. Restraint systems prevent workers from reaching the leading edge of a fall hazard. Always account for fully deployed length of lanyard/SRL. Structure must withstand loads applied in the directions permitted by the system of at least 1,000 lbs. No free fall is permitted. Restraint systems may only be used on surfaces with slopes up to 4/12 (vertical/horizontal). Applicable D-rings: Dorsal, Chest, Side, Shoulder.

For all applications: worker weight capacity range (including all clothing, tools, and equipment) is 130-310 lbs.

Limitations

Fall Clearance: There must be sufficient clearance below the anchorage connector to arrest a fall before the user strikes the ground or an obstruction. When calculating fall clearance, account for a MINIMUM 2' safety factor, deceleration distance, user height, length of lanyard/SRL, harness stretch, and all other applicable factors.

Diagram shown is an example fall clearance calculation ONLY.

Swing Falls: Prior to installation or use, make considerations for eliminating or minimizing all swing fall hazards. Swing falls occur when the anchor is not directly above the location where a fall occurs. Always work as close to in line with the anchor point as possible. Swing falls significantly increase the likelihood of serious injury or death in the event of a fall.

Fall clearance calculation shown based on standing worker falling directly in-line with anchor point. Always consider potential swing fall and other hazards when calculating fall clearance.

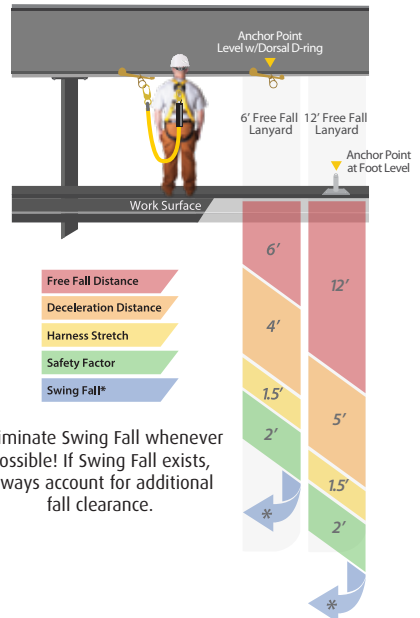

Compatibility: When making connections with 2-Way Standing Seam Roof Clamp, eliminate all possibility of roll-out. Roll-out occurs when interference between a hook and the attachment point causes the hook gate to unintentionally open and release. All connections must be selected and deemed compatible with 2-Way Standing Seam Roof Clamp by a Competent Person. All connector gates must be self-closing and self-locking, and withstand minimum loads of 3,600 lbs. See the following for examples of compatible/incompatible connections:

Connector closed and locked to D-ring. **OK.**



Connector to integral lanyard. **NO.**

Two connectors to same D-ring. **NO.**



Connector directly to webbing. **NO.**

Incompatible or irregular application, which may increase risk of roll-out. **NO.**



Connector directly to horizontal lifeline. **NO.**

Two or more snap hooks or carabiners connected to each other. **NO.**



Correct Anchorage Positioning:

This chart details allowable working zones required to reduce risk of swing falls and improper side loading. **ALWAYS** adhere to information specified by chart.

Anchor Distance From Leading Edge (Y)	Working Distance Along Roof Edge (Either Direction) (X)	Working Angle From Perpendicular (θ)
6'	8'	53°
10'	9' - 9"	45°
15'	11' - 7"	38°
20'	13' - 3"	33°
25'	14' - 6"	30°
30'	16'	28°
35'	17' - 2"	26°
40'	18' - 3"	24°
45'	19' - 4"	23°
50'	19' - 10"	21°
55'	21' - 4"	21°
60'	22' - 3"	21°

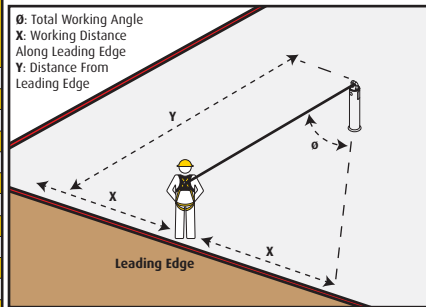

For example, if the anchorage connector is 6' from the leading edge (Y), the working distance (X) is 8' in each direction from the perpendicular, which translates to a 53° working angle.

Starting calculation point for determining correct anchorage positioning must be directly in-line with standing seam on which 2-Way Standing Seam Clamp is installed.

Components and Specifications

Materials: Zinc-plated steel.

3,600 lb. MBS (minimum breaking strength).

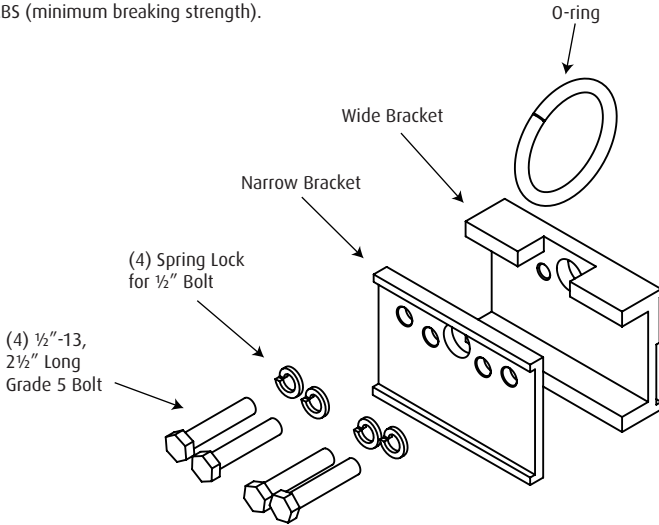

Installation and Use

Prior to installation, plan your system:

1. All PFAS equipment must be selected and deemed compatible with 2-Way Standing Seam Roof Clamp by a Competent Person.
2. Eliminate or minimize all risk of swing fall hazards.
3. Ensure installation location and work surface are free of all damage, including, but not limited to, corrosion, rot, rust, debris, and sharp or abrasive edges and surfaces.
4. Never for use in combination with horizontal lifelines (HLLs).



Prior to installation, a Qualified Person must determine 2-Way Standing Seam Roof Clamp is compatible with roof seam. Only install and use on a compatible standing seam metal roof (SSMR). See pgs. 6-8.

Installation:

1. 2-Way Standing Seam Roof Clamp is designed for use on a compatible standing seam roof ONLY. See pgs. 6-8.

2. 2-Way Standing Seam Roof Clamp MUST be attached to a fully seamed panel and MUST be attached over a clip that is bolted/screwed down.

3. A Qualified Person must make the final determination regarding roof compatibility.

4. 2-Way Standing Seam Roof Clamp must be positioned a minimum 4' from any/all fall hazards.

5. Hook 2-Way Standing Seam Roof Clamp flange under selected roof seam. This must be done before anchor bolts are tightened.

6. Tighten outside (2) bolts until snug, then tighten inside (2) bolts until snug.

7. Torque outside (2) bolts to 50 ft./lbs., then torque inside (2) bolts to 50 ft./lbs. Ensure 2-Way Standing Seam Roof Clamp is fully secured to roof seam and no possibility exists for detachment.

8. Attach complete and compatible PFAS to 2-Way Standing Seam Roof Clamp O-ring.

***2-Way Standing Seam Anchor may be installed in two different configurations. To fit to wider seam, remove all bolts and rotate anchor plate around O-ring to opposite side, then insert bolts and install as normal.**

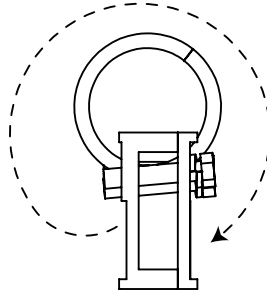
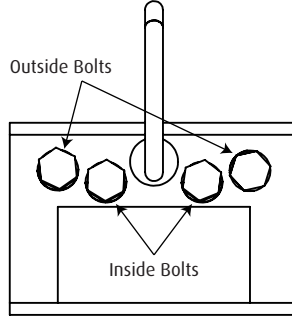

Compatible Standing Seam Metal Roofs (SSMR)

SSMR Manufacturer	SSMR Name	SSMR Thickness	SSMR Manufacturer	SSMR Name	SSMR Thickness
A&S	Double-Lok	22 gauge steel	Bryer Company	TBC-Ultra	22 gauge steel
A&S	DuraSeal Seam	22 gauge steel	Bryer Company	TBC-Ultra	24 gauge steel
A&S	DuraSeal Snap	22 gauge steel	Bryer Company	TBC-Superseam (Single Fold)	22 gauge steel
A&S	Ultra Dek	22 gauge steel	Bryer Company	TBC-Superseam (Double Fold)	22 gauge steel
A&S	DuraSeal Snap	24 gauge steel	Bryer Company	TBC-Superseam (Single Fold)	24 gauge steel
A&S	Ultra Dek	24 gauge steel	Butler	MR24	24 gauge steel
A&S	Double-Lok	24 gauge steel	Butler	VSR	24 gauge steel
A&S	DuraSeal Seam	24 gauge steel	Butler	MR24	22 gauge steel
AB Martin Roofing	AB Seam 19.5	24 gauge steel	Carlisle Engineered Metals, Inc.	Architectural Panel	22 gauge steel
AFP Span	Snap Seam	22 gauge steel	Carlisle Engineered Metals, Inc.	Architectural Panel	24 gauge steel
AFP Span	Snap Seam	22 gauge steel	Carlisle Engineered Metals, Inc.	VersaLok Panel	22 gauge steel
AFP Span	Span Seam (DBF)	22 gauge steel	Carlisle Engineered Metals, Inc.	VersaLok Panel	24 gauge steel
AFP Span	Multilok (Quad Lok)	24 gauge steel	CBC Steel Buildings	SS 24	24 gauge steel
AFP Span	Span Seam (DBF)	24 gauge steel	Ceco	CXP	22 gauge steel
AFP Span	Span Lok HP 2" SF	22 gauge steel	Ceco	CXP	24 gauge steel
AFP Span	Design Span hp	22 gauge steel	Ceco	CXP	22 gauge steel
All Weather Insulated Panels (AWIP)	5R Series (Single Fold)	24 gauge steel	Central States Manufacturing	Central Seam Plus	22 gauge steel
American Buildings Company	Loc Seam 360	22 gauge steel	Central States Manufacturing	Central Loc	22 gauge steel
American Buildings Company	Standing Seam 360	22 gauge steel	Central States Manufacturing	Central Loc	24 gauge steel
American Buildings Company	Loc Seam 360	22 gauge steel	Central States Manufacturing	Central Seam Plus	24 gauge steel
American Buildings Company	Standing Seam II Panel	22 gauge steel	Central States Manufacturing	ShurLoc 175	24 gauge steel
Architectural Building Components	Permasseam	22 gauge steel	Central Texas Metal Roofing Supply	SDP 175	22 gauge steel
Architectural Building Components	Permasseam	24 gauge steel	Centria	SDP 175	24 gauge steel
Architectural Building Components	Permasseam	22 gauge steel	Centria	SDP 200	24 gauge steel
Architectural Building Components	Permasseam	24 gauge steel	Centria	SDP 300	24 gauge steel
Architectural Building Components	Permasseam	24 gauge steel	Centria	MSC Panel	22 gauge steel
Architectural Metal Specialties, Inc.	AMS175 1-3/4" Snap-Lock	24 gauge steel	Chief Industries	STC Panel	22 gauge steel
Architectural Metal Specialties, Inc.	AMS175 1-3/4" Snap-Lock	24 gauge steel	Chief Industries	STC Panel	24 gauge steel
Architectural Metal Specialties, Inc.	UltraSeam US17LS Snap-Lock	22 gauge steel	Chief Industries	MSC Panel	24 gauge steel
ASC Building Products	Sterling Roof System	22 gauge steel	Chief Industries	MSC Panel	22 gauge steel
Associated Building Systems	KA-2000	24 gauge steel	Classic Roofing Systems	CR-S 38 (Single Fold)	22 gauge steel
Associated Building Systems	KA-2000	24 gauge steel	Classic Roofing Systems	CR-S 25 (Single Fold)	22 gauge steel
ATAS	2" Field-Lok	22 gauge steel	Construction Metals, Inc.	Sur-Lock	22 gauge steel
Box Steel Buildings	Box-Lock	22 gauge steel	Construction Metals, Inc.	Barrier Roof	22 gauge steel
Box Steel Buildings	Box-Lock	22 gauge steel	Construction Metals, Inc.	Barrier Roof	24 gauge steel
Box Steel Buildings, Inc.	Box-Lock	22 gauge steel	Construction Metals, Inc.	Sur-Lock	24 gauge steel
Box Steel Buildings, Inc.	Box-Lock	24 gauge steel	Construction Metals, Inc.	Sur-Lock	24 gauge steel
Box Steel Buildings	BCL 24-MS	22 gauge steel	Copper Sales	UC4	24 gauge steel
BC Steel Buildings	BCL 24-SD	22 gauge steel	Corle Building Systems	Seam-Lok	22 gauge steel
BC Steel Buildings	BCL 24-SD	24 gauge steel	Corle Building Systems	Seam-Lok	24 gauge steel
BC Steel Buildings	BCL 24-MS	24 gauge steel	Corle Building Systems	Snap-Seal	24 gauge steel
Behlen Building Systems	ZL-24 Triple-Lock	24 gauge steel	Corle Building Systems	Snap-Seal	24 gauge steel
Behlen Building Systems	ZL-16 Triple-Lock	22 gauge steel	Custom Blitt Metals	Seam-Lok	24 gauge steel
Behlen Building Systems	Cee-Lock	24 gauge steel	Custom Blitt Metals	SL 1750 NT	24 gauge steel
Behlen Building Systems	Cee-Lock	24 gauge steel	Custom Blitt Metals	CB 150 (Double Fold) NT	22 gauge steel
Bertrigo		24 gauge steel	Dean Steel Buildings, Inc.	Pro Seam Panel	22 gauge steel

Compatible Standing Seam Metal Roofs (SSMR)

SSMR Manufacturer	SSMR Name	SSMR Thickness	SSMR Manufacturer	SSMR Name	SSMR Thickness
Dean Steel Buildings, Inc	Pro Seam Panel	24 gauge steel	Kirby Building Systems	SSMR 2000	24 gauge steel
Dimensional Metals	SL-25	22 gauge steel	Kirby Building Systems	Kirbylok 2000 MS	24 gauge steel
Dimensional Metals	IL-20	24 gauge steel	Knudson Building Systems	KR-20	24 gauge steel
Dimensional Metals	DL-15	24 gauge steel	Laura Star-Roof, BV	Spanlok	22 gauge steel
Drexel Metals	DMC 1755 Snap Lock 1-3/4	24 gauge steel	Laura Star-Roof, BV	Artlock	22 gauge steel
Drexel Metals	DMC 2105 (Armo Style)	22 gauge steel	MBCI	Artlock	24 gauge steel
Drexel Metals	DMC 1755 Snap Lock 1-3/4	22 gauge steel	MBCI	LoSeam	22 gauge steel
Drexel Metals	DMC 2005 2" Double Fold	22 gauge steel	MBCI	DoubleLok	22 gauge steel
Drexel Metals	DMC 2105 (Armo Style)	22 gauge steel	MBCI	LoSeam	24 gauge steel
Drexel Metals	DMC 1505S (Double Fold)	22 gauge steel	MBCI	LoSeam	22 gauge steel
Drexel Metals	DMC 1755 Snap Lock 1-3/4	24 gauge steel	MBCI	UltraDek	22 gauge steel
Englert	Series 2000	22 gauge steel	MBCI	DoubleLok	24 gauge steel
Englert	Series 2500 (Double Fold)	22 gauge steel	MBCI	LoSeam	24 gauge steel
Englert	Series 2000	22 gauge steel	MBCI	SuperLok	22 gauge steel
Englert	Series 2400 (Double Fold)	22 gauge steel	MBCI	BattenLok	22 gauge steel
Englert	Series 2000	22 gauge steel	MBCI	BattenLok	24 gauge steel
Englert	Series 1300	22 gauge steel	McElroy Metal	Maxima 1.5"	22 gauge steel
Fab Tech, Inc.	Seam-Lok	22 gauge steel	McElroy Metal	Medallion-Lok	22 gauge steel
Fab Tech, Inc.	Snap-Seal	22 gauge steel	McElroy Metal	Maxima 2" ADV	22 gauge steel
Fab Tech, Inc.	Snap-Seal	24 gauge steel	McElroy Metal	Medallion-Lok	24 gauge steel
Fab Tech, Inc.	Snap-Seal	24 gauge steel	McElroy Metal	Medallion-Lok	24 gauge steel
Fabral	Thin Seam	24 gauge steel	McElroy Metal	Master-Lok 90 (ML90)	22 gauge steel
Fabral	Stand N Seam	24 gauge steel	McElroy Metal	Master-Lok 90 (ML90)	22 gauge steel
Fabral	3" Snap Rib	24 gauge steel	McElroy Metal	Maxima 1.5"	24 gauge steel
Firestone	UC14	24 gauge steel	McElroy Metal	Medallion-Lok	24 gauge steel
Firestone	UC4	24 gauge steel	McElroy Metal	Maxima 2" ADV	24 gauge steel
Follansbee Steel	1in (25mm) DF (TCS)	.018 TCS II	Merchant & Evans	ML-ES	22 gauge steel
Galvak, S.A. De C.V.	Galvalok II	22 gauge steel	Merchant & Evans	Interlock	24 gauge steel
Galvak, S.A. De C.V.	Galvalok I	24 gauge steel	Merchant & Evans	.040 aluminum	24 gauge steel
Galvak, S.A. De C.V.	Galvalok I	24 gauge steel	Merchant & Evans	#305	24 gauge steel
Galvak, S.A. De C.V.	Galvalok II	24 gauge steel	Merchant & Evans	#305	.040 aluminum
Galvak, S.A. De C.V.	Galvalok II	24 gauge steel	Mesco	Double-Lok	22 gauge steel
Garco Building Systems	Garco Standing Seam	22 gauge steel	Mesco	Ultra Dek	22 gauge steel
Garco Building Systems	Garco Standing Seam	24 gauge steel	Mesco	Ultra Dek	24 gauge steel
Garland	R-Mer Loc	22 gauge steel	Mesco	Double-Lok	24 gauge steel
Imetco	Snap Lok 1-3/4"	22 gauge steel	Metal Sales	Vertical Seam	22 gauge steel
Inland Buildings	IN-LOC	24 gauge steel	Metal Sales	Vertical Seam	24 gauge steel
Interlock Roofing	Snap Lock 1"	.027 aluminum	Metal Sales	Vertical Seam	22 gauge steel
Interlock Roofing	Future Roof 1.5" SF	26 gauge steel	Metal-Fab Manufacturing	Magna Loc	22 gauge steel
Kingspan USA	KingZip 1020	22 gauge steel	Metal-Fab Manufacturing	MetFab Snap-On 675	24 gauge steel
Kirby Building Systems	Kirbylok 2000 MS	22 gauge steel	Metal-Fab Manufacturing	MetFab III Panel	22 gauge steel
Kirby Building Systems	Kirbylok 2000	22 gauge steel	Metal-Fab Manufacturing	MetFab III Panel	24 gauge steel
Kirby Building Systems	Kirbylok 2000	22 gauge steel	Metal-Fab Manufacturing	MetFab Historic Panel 1.5" DBF	22 gauge steel

Compatible Standing Seam Metal Roofs (SSMR)

SSMR Manufacturer	SSMR Name	SSMR Thickness	SSMR Manufacturer	SSMR Name	SSMR Thickness
Metal-Fab Manufacturing	MeFab Snap-on 550 Panel	24 gauge steel	Steel Span, Inc.	Architectural	24 gauge steel
Morin	SLR	22 gauge steel	Steelco	Sur-Lock	22 gauge steel
Morin	SWL	22 gauge steel	Steelco	Barrier Roof Panels	22 gauge steel
Morin	SLR	24 gauge steel	Steelco	Barrier Roof Panels	24 gauge steel
Morin	SWL	24 gauge steel	Steelco	Sur-Lock	24 gauge steel
NG/Midwest Metallic	Double-Lok	22 gauge steel	Steelway Building Systems	RTL-24 Quad Loc	22 gauge steel
NG/Midwest Metallic	Weather Roof III	22 gauge steel	Steelway Building Systems	RTL-24 Quad Loc	22 gauge steel
NG/Midwest Metallic	Ultra Dek	22 gauge steel	Taylor Metals	Versa-Span	24 gauge steel
NG/Midwest Metallic	Weather Roof II	22 gauge steel	Taylor Metals	MS 200	22 gauge steel
NG/Midwest Metallic	Ultra Dek	24 gauge steel	Taylor Metals	MS 200	24 gauge steel
NG/Midwest Metallic	Weather Roof II	24 gauge steel	Tremco	Tremlock LSP	22 gauge steel
NG/Midwest Metallic	Double-Lok	24 gauge steel	Triad Corrugated Metal, Inc.	Snap Lock 1-3/4	24 gauge steel
NG/Midwest Metallic	Weather Roof III	24 gauge steel	U.S. Metals	US-179LS	22 gauge steel
NG/Midwest Metallic	216	22 gauge steel	U.S. Metals	US-179LS	24 gauge steel
NG/Midwest Metallic	BattenLok	22 gauge steel	U.S. Metals	US-150	22 gauge steel
NG/Midwest Metallic	216	24 gauge steel	Una-Clad	UC14	24 gauge steel
NG/Midwest Metallic	BattenLok	24 gauge steel	Una-Clad	UCA	24 gauge steel
New Tech Machinery	SS 675 Snap Lock 1-3/4	24 gauge steel	Union Corrugating Company	MLE50 (Double Fold)	22 gauge steel
New Tech Machinery	SS 210A (Amico Style) 2	22 gauge steel	Union Corrugating Company	SL150	24 gauge steel
New Tech Machinery	SS 210A (Amico Style) 2	24 gauge steel	United Structures of America	Guardian II	22 gauge steel
New Tech Machinery	SS 150 (Double Fold)	22 gauge steel	United Structures of America	Guardian I	22 gauge steel
New Tech Machinery	SS 675 Snap Lock 1-3/4	24 gauge steel	United Structures of America	Guardian I	24 gauge steel
New Tech Machinery	SS 550 Snap Lock 1 1/2	24 gauge steel	United Structures of America	Guardian II	24 gauge steel
Nu Ray Metals	Series 2000 Standing Seam	24 gauge steel	Varco Pruden	SSR	24 gauge steel
Nucor Building Systems	VR16-1Visee-Lock 360	24 gauge steel	Varco Pruden	SLR	22 gauge steel
Nucor Building Systems	CFR Visee Lock 360 Seam	24 gauge steel	Whirwind Building Systems	Super Seam Plus	22 gauge steel
OC Metals	OCM175 SL	24 gauge steel	Whirwind Building Systems	Super Seam II	22 gauge steel
OC Metals	OCM175 SL	24 gauge steel	Whirwind Building Systems	Super Seam II	24 gauge steel
Petersen Aluminum Corp	Snap Clad	24 gauge steel	Whirwind Building Systems	Super Seam Plus	24 gauge steel
Petersen Aluminum Corp	Snap Clad	22 gauge steel	Zamil Steel Industries	Max Seam	22 gauge steel
Petersen Aluminum Corp	Snap Clad	22 gauge steel	Zamil Steel Industries	Max Seam	24 gauge steel
Petersen Aluminum Corp	Snap Clad	24 gauge steel	Zamil Steel Industries	Max Seam	24 gauge steel
Petersen Aluminum Corp	Tite-Loc Plus	22 gauge steel	Zimmerman Metals, Inc.	SL1750	22 gauge steel
Petersen Aluminum Corp	Tite-Loc	24 gauge steel	Zimmerman Metals, Inc.	SL1750	24 gauge steel
Petersen Aluminum Corp	Tite-Loc	24 gauge steel			
Rigid Global Buildings	Platinum Series Quad-Lok	24 gauge steel			
Rigid Global Buildings	Hi-Tech Series Quad-Lok	24 gauge steel			
Robertson Building Systems	Starshield-SSR	24 gauge steel			
Schulte Building Systems	TS-324 TripleLok	24 gauge steel			
Star	Starshield	24 gauge steel			
Steel Span, Inc.	Trapezoidal	22 gauge steel			
Steel Span, Inc.	Trapezoidal	24 gauge steel			
Steel Span, Inc.	Architectural	22 gauge steel			

Maintenance, Cleaning, and Storage

If 2-Way Standing Seam Roof Clamp fails inspection in any way, immediately remove it from service, and contact Guardian to inquire about its return or repair.

Cleaning after use is important for maintaining the safety and longevity of 2-Way Standing Seam Roof Clamp. Remove all dirt, corrosives, and contaminants from 2-Way Standing Seam Roof Clamp before and after each use. If 2-Way Standing Seam Roof Clamp cannot be cleaned with plain water, use mild soap and water, then rinse and wipe dry. NEVER clean 2-Way Standing Seam Roof Clamp with corrosive substances.

When not in use, store equipment where it will not be affected by heat, light, excessive moisture, chemicals, or other degrading elements.

Inspection

Prior to EACH use, inspect 2-Way Standing Seam Roof Clamp for deficiencies, including, but not limited to, corrosion, deformation, pits, burrs, rough surfaces, sharp edges, cracking, rust, paint buildup, excessive heating, alteration, and missing or illegible labels. IMMEDIATELY remove 2-Way Standing Seam Roof Clamp from service if defects or damage are found, or if exposed to forces of fall arrest.

Ensure that applicable work area is free of all damage, including, but not limited to, debris, rot, rust, decay, cracking, and hazardous materials. Ensure that selected work area will support the application-specific minimum loads set forth in this instruction manual. Work area MUST be stable.

At least every 12 months, a Competent Person other than the user must inspect 2-Way Standing Seam Roof Clamp. **Competent Person inspections MUST be recorded in inspection log in instruction manual and on equipment inspection grid label. The Competent Person must sign their initials in the box corresponding to the month and year the inspection took place.**

During inspection, consider all applications and hazards 2-Way Standing Seam Roof Clamp have been subjected to.

Inspection Log

Date of First Use: _____.

Product lifetime is indefinite as long as it passes pre-use and Competent Person inspections. User must inspect prior to EACH use. Competent Person other than user must complete formal inspection at least every 12 months. Competent Person to inspect and initial.

This inspection log must be specific to one 2-Way Standing Seam Roof Clamp. Separate inspection logs must be used for each 2-Way Standing Seam Roof Clamp. All inspection records must be made visible and available to all users at all times.

	J	F	M	A	M	J	J	A	S	O	N	D
YR												
YR												
YR												
YR												
YR												

If equipment fails inspection IMMEDIATELY REMOVE FROM SERVICE.

Safety Information



Failure to understand and comply with safety regulations may result in serious injury or death. Regulations included herein are not all-inclusive, are for reference only, and are not intended to replace a Competent Person's judgment or knowledge of federal or state standards.

Do not alter equipment. Do not misuse equipment.

Workplace conditions, including, but not limited to, flame, corrosive chemicals, electrical shock, sharp objects, machinery, abrasive substances, weather conditions, and uneven surfaces, must be assessed by a Competent Person before fall protection equipment is selected.

The analysis of the workplace must anticipate where workers will be performing their duties, the routes they will take to reach their work, and the potential and existing fall hazards they may be exposed to. Fall protection equipment must be chosen by a Competent Person. Selections must account for all potential hazardous workplace conditions. All fall protection equipment should be purchased new and in an unused condition.

Fall protection systems must be selected and installed under the supervision of a Competent Person, and used in a compliant manner. Fall protection systems must be designed in a manner compliant with all federal, state, and safety regulations. Forces applied to anchors must be calculated by a Competent Person.

Unless explicitly stated otherwise, the maximum allowable free fall distance for lanyards must not exceed 6'. No free fall allowed for non-LE SRLs. Class A SRLs must arrest falls within 24"; Class B SRLs must arrest falls within 54".

Harnesses and connectors selected must be compliant with manufacturer's instructions, and must be of compatible size and configuration. Snap hooks, carabiners, and other connectors must be selected and applied in a compatible fashion. All risk of disengagement must be eliminated. All snap hooks and carabiners must be self-locking and self-closing, and must never be connected to each other.

A pre-planned rescue procedure in the case of a fall is required. The rescue plan must be project-specific. The rescue plan must allow for employees to rescue themselves, or provide an alternative means for their prompt rescue. Store rescue equipment in an easily accessible and clearly marked area.

Training of Authorized Persons to correctly erect, disassemble, inspect, maintain, store, and use equipment must be provided by a Competent Person. Training must include the ability to recognize fall hazards, minimize the likelihood of fall hazards, and the correct use of personal fall arrest systems.

NEVER use fall protection equipment of any kind to hang, lift, support, or hoist tools or equipment, unless explicitly certified for such use.

Equipment subjected to forces of fall arrest must immediately be removed from use.

Age, fitness, and health conditions can seriously affect the worker should a fall occur. Consult a doctor if there is any reason to doubt a user's ability to withstand and safely absorb fall arrest forces or perform set-up of equipment. Pregnant women and minors must not use this equipment.

Physical harm may still occur even if fall safety equipment functions correctly. Sustained post-fall suspension may result in serious injury or death. Use trauma relief straps to reduce the effects of suspension trauma.

Labels

<p>GUARDIAN FALL PROTECTION</p> <p>90130 (Rev. C) Made in China</p> <p>Compliant with OSHA 1910 and 1926 Subpart M regulations.</p> <p>Materials: Zinc-plated steel.</p> <p>Weight capacity: 130-310 lbs. 3,600 lb. min. breaking strength.</p>	<p>2-Way Standing Seam Roof Clamp</p> <p>Part # 10600</p> <p>800-466-6385 • www.guardianfall.com</p> <p>PRIOR TO USE, READ AND UNDERSTAND MANUFACTURER'S INSTRUCTIONS PROVIDED WITH EQUIPMENT.</p> <p>SEE INSTRUCTIONS FOR COMPATIBLE STANDING SEAM METAL ROOFS.</p>	<p>Date of Manufacture: </p> <p>Serial #: </p> <p>WARNING</p> <p>Only make compatible connections. Maximum 1 connection per anchor. Avoid contact with hazards, including, but not limited to, heat, chemicals, electricity, and sharp or abrasive edges and surfaces.</p>
--	--	---

INSPECTION GRID	<p>User must inspect prior to EACH use. Competent Person must complete formal inspection every 12 months. Competent Person to inspect and initial.</p> <p>Date of First Use: _____ Product lifetime is indefinite as long as equipment passes pre-use and Competent Person inspections.</p> <table border="1" style="width: 100%; border-collapse: collapse; text-align: center;"> <thead> <tr> <th>YR</th> <th>J</th> <th>F</th> <th>M</th> <th>A</th> <th>M</th> <th>J</th> <th>J</th> <th>A</th> <th>S</th> <th>O</th> <th>N</th> <th>D</th> </tr> </thead> <tbody> <tr><td>20__</td><td></td><td></td><td></td><td></td><td></td><td></td><td></td><td></td><td></td><td></td><td></td><td></td></tr> <tr><td>20__</td><td></td><td></td><td></td><td></td><td></td><td></td><td></td><td></td><td></td><td></td><td></td><td></td></tr> <tr><td>20__</td><td></td><td></td><td></td><td></td><td></td><td></td><td></td><td></td><td></td><td></td><td></td><td></td></tr> <tr><td>20__</td><td></td><td></td><td></td><td></td><td></td><td></td><td></td><td></td><td></td><td></td><td></td><td></td></tr> <tr><td>20__</td><td></td><td></td><td></td><td></td><td></td><td></td><td></td><td></td><td></td><td></td><td></td><td></td></tr> </tbody> </table>	YR	J	F	M	A	M	J	J	A	S	O	N	D	20__													20__													20__													20__													20__													<p style="writing-mode: vertical-rl; transform: rotate(180deg);">If equipment fails inspection, IMMEDIATELY REMOVE FROM SERVICE</p>	<p style="background-color: yellow; color: black; padding: 5px;">DO NOT REMOVE LABELS</p>
YR	J	F	M	A	M	J	J	A	S	O	N	D																																																																					
20__																																																																																	
20__																																																																																	
20__																																																																																	
20__																																																																																	
20__																																																																																	

